

DVS3000 INSTALLATION GUIDE

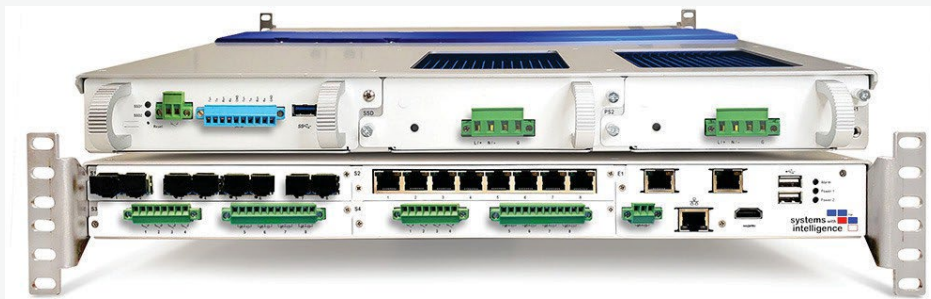

SUBSTATION-GRADE DIGITAL VIDEO SERVER

VERSION 1.0 - 2024-06-14

Note: Please read this manual thoroughly before operating this unit and retain it for future reference.

TOUCHLESS™ MONITORING SOLUTIONS

COMPANY NAME :

SYSTEMS WITH INTELLIGENCE INC..

ADDRESS :

N: Systems With Intelligence Inc
A: 6889 Rexwood Road, Unit 9
Mississauga, ON, Canada
L4V 1R2

CONTACT :

P: +1-289-562-0126
W: www.systemswithintelligence.com
M: support@systemswithintelligence.com

Copyright

COPYRIGHT © 2024 Systems With Intelligence Inc. ALL RIGHTS RESERVED

Dissemination or reproduction of this document, or evaluation and communication of its contents, is not authorized except where expressly permitted. Violations are liable for damages. All rights reserved, particularly for the purposes of patent application or trademark registration.

This document contains proprietary information, which is protected by copyright. All rights are reserved. No part of this document may be photocopied, reproduced or translated to another language without the prior written consent of Systems With Intelligence Inc.

Disclaimer of Liability

We have checked the contents of this manual against the hardware and software described. However, deviations from the description cannot be completely ruled out.

Systems With Intelligence shall not be liable for any errors or omissions contained herein or for consequential damages in connection with the furnishing, performance, or use of this material.

The information given in this document is reviewed regularly and any necessary corrections will be included in subsequent editions. We appreciate any suggested improvements. We reserve the right to make technical improvements without notice.

Contacting Systems With Intelligence



6889 Rexwood Road, Unit #9, Mississauga, Ontario, L4V 1R2

Canada Phone: +1-289-562-0126 Email:

info@SystemsWithIntelligence.com

www.SystemsWithIntelligence.com

Technical Support

International +1-289-562-0126 Fax: +1-289-562-0152

Email: support@SystemsWithIntelligence.com

Federal Communications Commission Radio Frequency Interference Statement

This equipment has been tested and found to comply with the limits for a Class A digital device pursuant to Part 15 of the FCC Rules. These limits are designed to provide reasonable protection against harmful interference when the equipment is operated in a commercial environment. This equipment generates, uses and can radiate radio frequency energy and, if not installed and used in accordance with the instruction manual, may cause harmful interference to radio communications. Operation of this equipment in a residential area is likely to cause harmful interference in which case the user will be required to correct the interference on his own expense.

CAUTION

This product contains a laser system and is classified as a

“CLASS 1 LASER PRODUCT”

CAUTION

Use of controls or adjustments or performance of procedures other than those specified herein may result in hazardous radiation exposure. This product contains no user-serviceable parts. Attempted service by unauthorized personnel shall render all warranties null and void.

Changes or modifications not expressly approved by Systems With Intelligence Inc. could void the user's authority to operate the equipment.

Should this device require service please contact SWI.

IMPORTANT

The DVS3000 family of products should be installed in a **restricted access location** where access can only be gained by service personnel or users who have been instructed about the reasons for the restrictions applied to the location and about any precautions that shall be taken; and access is through the use of a tool or lock and key, or other means of security, and is controlled by the authority responsible for the location.

Table of Contents

1	Product Overview	5
	1.1 Front & Rear Diagram	5
	1.2 Technical Specifications Overview	6
2	Dimensions	7
3	Front Panel Display.....	8
	3.1 Power Supply	8
	3.2 Alarm 8	8
4	Power Supply	9
	4.1 AC Power Supply Wiring Examples.....	10
	4.2 DC Power Supply Wiring Examples	10
5	Ethernet Ports	11
	5.1 Copper Ports	11
	5.2 Copper Gigabit Ethernet 1000Base-TX Cabling Recommendations.....	11
6	RS485 Serial Interface.....	13
	6.1 RS485 Half-duplex: 2-wires connections	13
	6.2 RS485-duplex: 4-wires connections.....	14
7	TOD0: 4in/4out - Digital I/O Interface	15
	7.1 Dry Contact Input Interface Connector	15
	7.2 Relay Output Interface Connectors	15
8	Ancillary equipment connections	16
	8.1 Fail Safe Relay	16
	8.2 Remote Reset Input.....	16
9	Maintenance	17
	9.1 Install/replace Power Supply Module.....	17
	9.2 Install replace Hard Disk.....	18
10	Environmental Specifications	20
	10.1 Temperature & Humidity	20
	10.2 EMC/EMI/ESD	20
	10.3 EMI TYPE TESTS	21
	10.4 EMI IMMUNITY TYPE TESTS	22

1 Product Overview

1.1 Front & Rear Diagram

FRONT VIEW

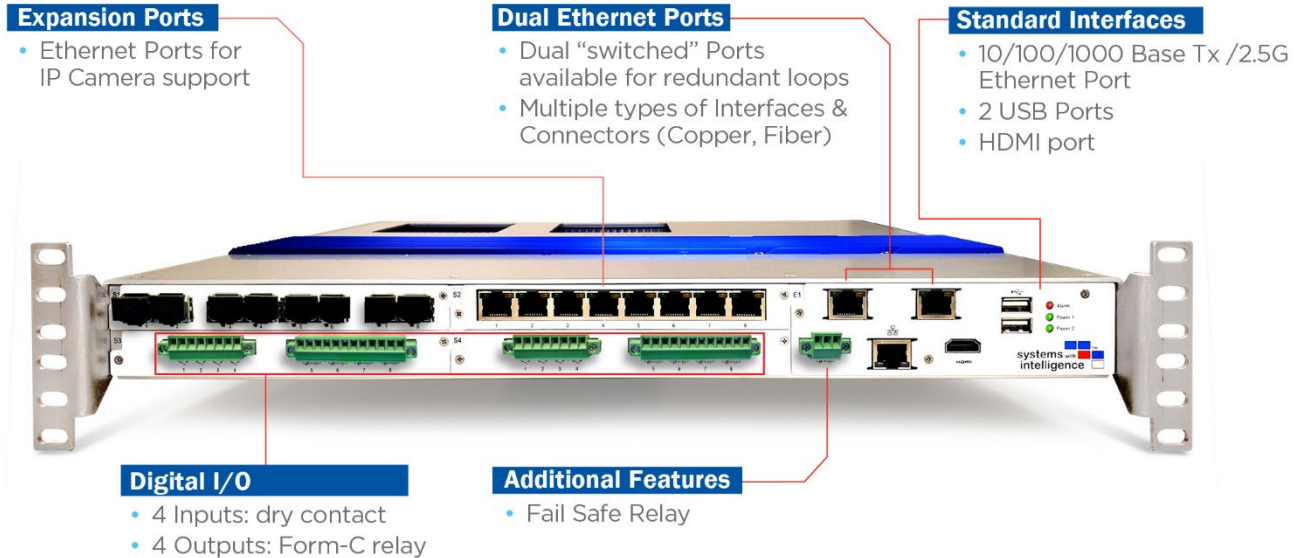

REAR VIEW

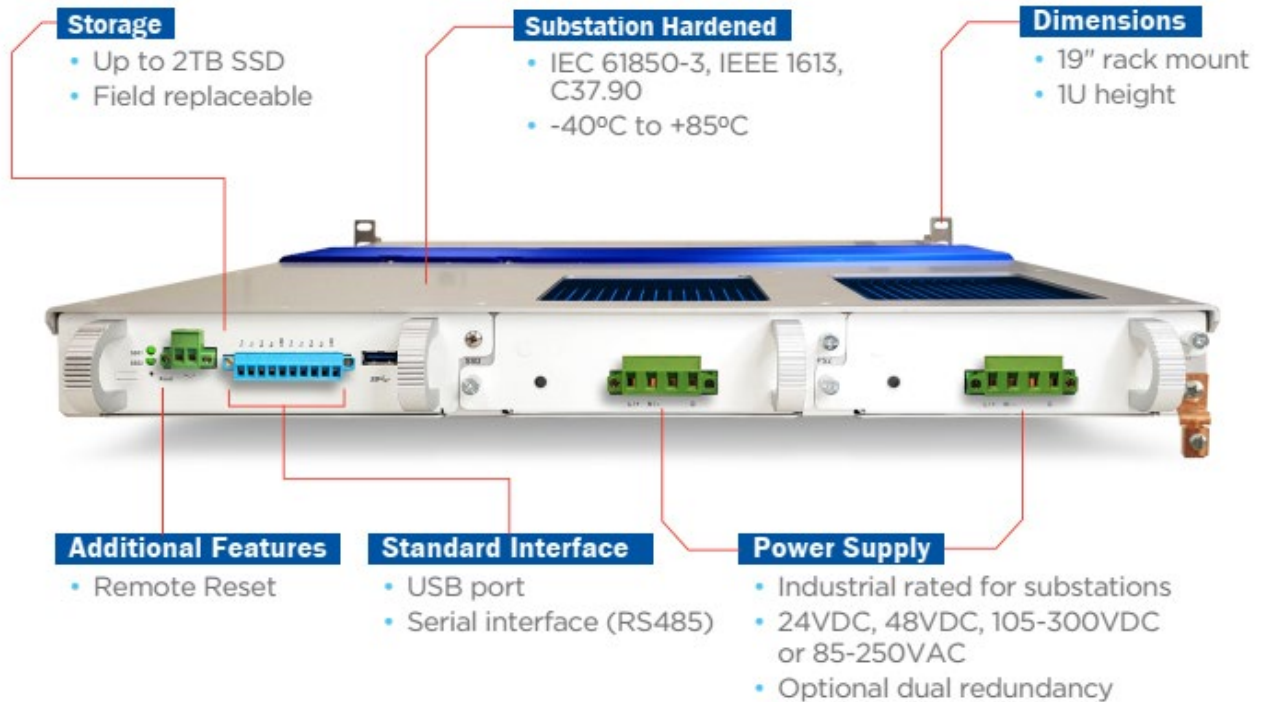

1.2 Technical Specifications Overview

Table 1-1 Specifications

SPECIFICATIONS	
IP Cameras	<ul style="list-style-type: none"> Up to 16 IP cameras can be connected to the DVS IP Camera support for leading manufacturers (Contact Systems With Intelligence for the latest list of supported IP Cameras) H.264 video streaming Resolution and frame rate dependent on IP camera used HD and megapixel images supported ONVIF IP Camera Support
Video Output	1 X HDMI
USB Storage	4 USB Ports Up to 2TB using solid state drives
LAN Interface	Included: 1-port 10/100/1000TX RJ45 Interface/2.5 Gbps Optional: 2-ports 10/100/1000TX RJ45 or 100FX Fiber Interface
Power Supply	24VDC, 48VDC, 105 -300VDC or 85-250VAC; Optional dual redundant power supplies
Operating Temperature	-40° C to +85° C; no cooling fans
EMC/EMI	IEC 61850-3; IEEE 1613; IEC 61000-6-2; IEC 61800-3
Mounting/Dimensions	19" Rack Mount; 2U height
Warranty	2 Years

2 Dimensions

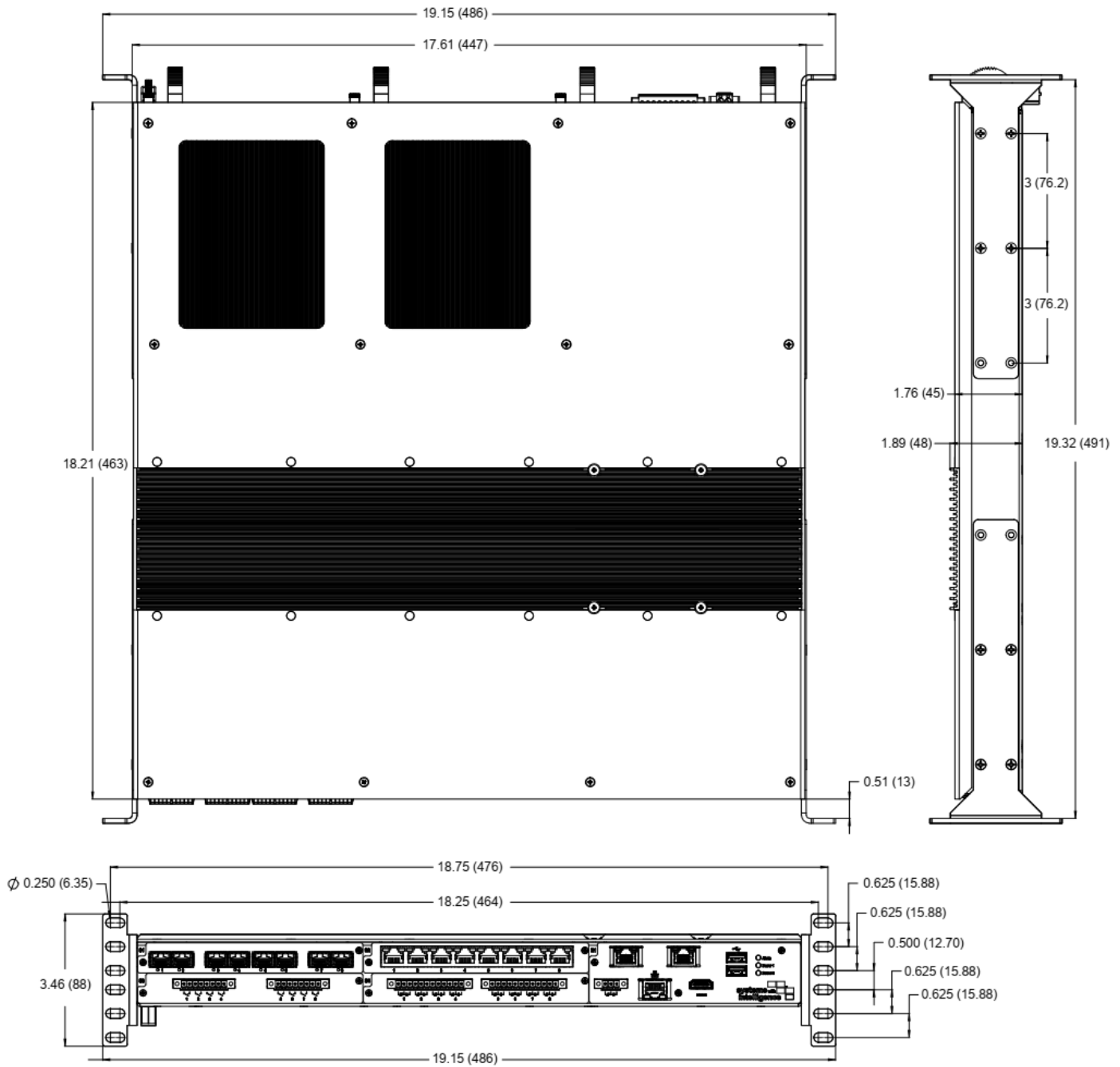

* **Note:** Units in Imperial (Metric).

Figure 2-1 Dimensions

3 Front Panel Display

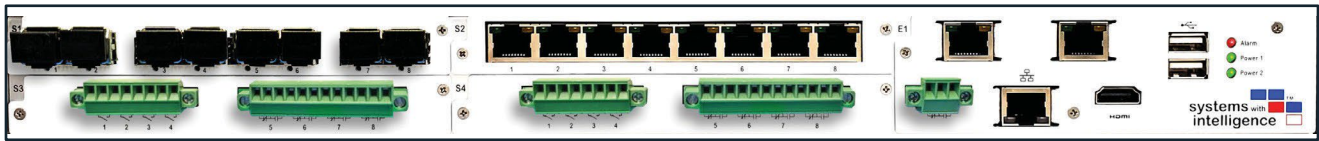

Figure 3-1 Front Panel

3.1 Power Supply

- **Green:** Power Supply Normal
- **Red:** Power Supply Fault
- **OFF:** Power Supply Not present

Power Supply 2: (same as Power 1)

3.2 Net

Built-in port is located at the bottom	Left	Right	Connection
	OFF	Yellow (blink)	2.5G base T
	OFF	Yellow (blink)	1000 base T
	Yellow	OFF	100 base T
	OFF	Green (blink)	10 base T
	OFF	OFF	no link

E1 ports are located at the top	Left	Right	Connection
	Green (blink)	Yellow (blink)	1000 base T
	OFF	Yellow (blink)	100 base T
	Green (blink)	OFF	10 base T
	OFF	OFF	no link

S1 and S2 ports	Left	Right	Connection
	OFF	Yellow (blink)	100 base T
	Green (blink)	OFF	10 base T
	OFF	OFF	no link

3.3 Alarm

- **Red:** Unit alarm
- **OFF:** Unit normal

4 Power Supply

Table 4-1 Power Supply Models

POWER SUPPLY TYPE	INPUT RANGE		INTERNAL FUSE RATING	POWER CONSUMPTION	
	MIN	MAX		TYPICAL	WORST CASE
24/48 VDC	20 VDC	60 VDC	5A(T)	35 W - 40 W	80 W - 90 W
HI (125/250 VDC)	105 VDC	300 VDC	5A(T)		
HI (110/230 VAC)	85 VAC	250 VAC			

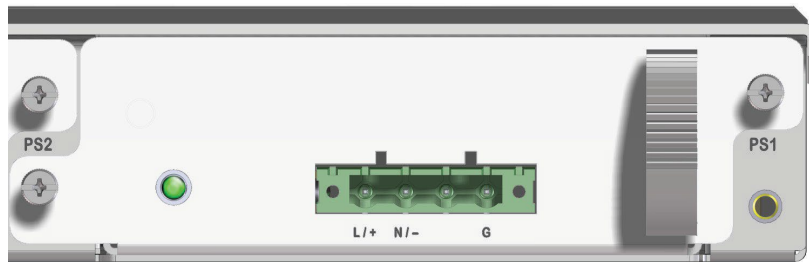

Figure 4-1 Power Supply 1

Table 4-2 Terminals Description

TERMINAL NUMBER	DESCRIPTION	USAGE
Ground Lug Screw	Chassis Ground	Chassis Ground is connected to the Safety Ground terminal for AC inputs or the equipment ground bus for DC inputs..
PIN 1	Live / +	PS Live / + is connected to the positive (+) terminal if the power source is DC or to the (Live) terminal if the power source is AC.
PIN 2	Neutral / -	PS Neutral / - is connected to the negative (-) terminal if the power source is DC or to the (Neutral) terminal if the power source is AC.
PIN 3	Not connected	
PIN 4	Surge Ground	PS2 Surge Ground is connected to the Chassis Ground via a jumper on the terminal block. Surge Ground is used as the ground conductor for all surge and transient suppression circuitry.

4.1 AC Power Supply Wiring Examples

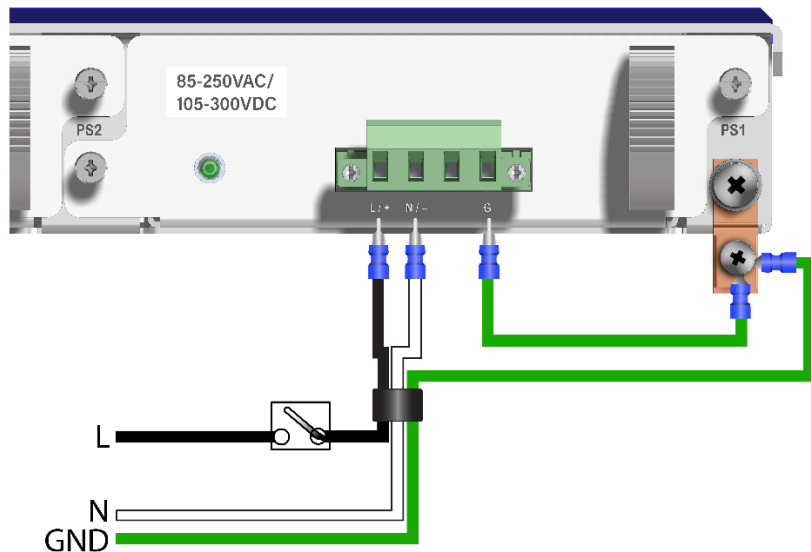

Figure 4-2 AC Power Supply connections

Notes:

- 85-250 VAC rated equipment:
- An appropriately rated circuit breaker must be installed
- Equipment must be installed according to the applicable country wiring codes.
- When equipped with two HI voltage power supplies, independent AC sources can be used to power the product for greater redundancy.

4.2 DC Power Supply Wiring Examples

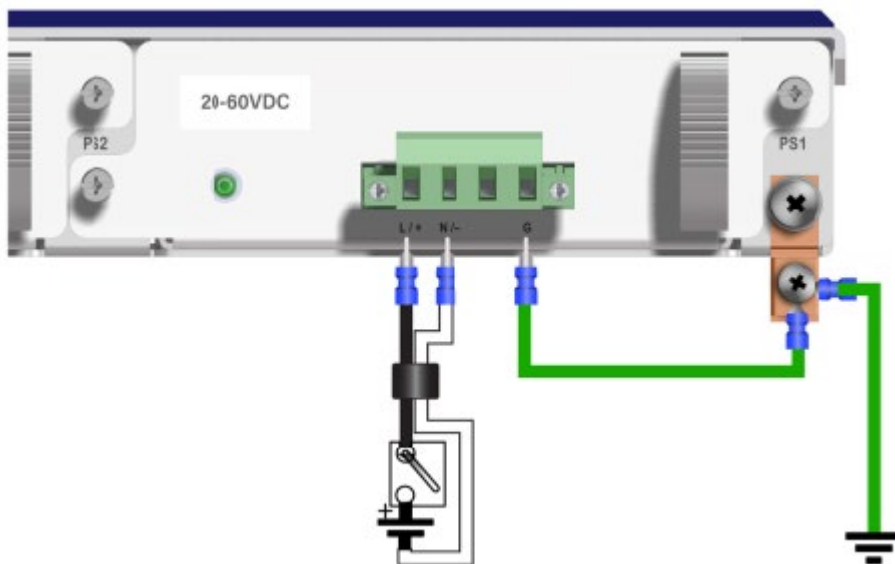

Figure 4-3 DC Power Supply connections

Notes:

- 105-300VDC rated equipment: An appropriately rated circuit breaker must be installed.
- A circuit breaker is not required for 24 or 48 VDC rated power supplies.
- For dual DC power supplies, Separate circuit breakers must be installed and separately identified.
- Equipment must be installed according to the applicable country wiring codes.

5 Ethernet Ports

5.1 Copper Ports

The DVS3000 has an IEEE 802.3 Ethernet Interface for 2.5GBase-T, 1000Base-T, 100Base-TX, and 10Base-T applications (802.3, 802.3u, 802.3ab and 802.3bz) conformance. The RJ45 Ethernet ports features auto negotiating, and auto- crossover functions. The following figure shows the RJ45 port pins configuration.



PIN	SIGNAL 10/100 TX	SIGNAL 1000TX
1	+Rx	BI_DA+
2	- Rx	BI_DA-
3	+Tx	BI_DB+
4	No Connection	BI_DB-
5	No Connection	BI_DC+
6	-Tx	BI_DC-
7	No Connection	BI_DD+
8	No Connection	BI_DA-

5.2 Copper Gigabit Ethernet 1000Base-TX Cabling Recommendations

The IEEE 802.3ab Gigabit Ethernet standard defines 1000 Mbps Ethernet communications over distances of up to 100 meters using 4 pairs of category 5 (or higher) balanced unshielded twisted-pair cabling. For wiring guidelines, system designers and integrators should refer to the Telecommunications Industry Association (TIA) TIA/EIA-568-A wiring standard that characterizes minimum cabling performance specifications required for proper Gigabit Ethernet operation. To ensure reliable, error-free data communications, new and pre-existing communication paths should be verified for TIA/EIA-568-A compliance.

In general, the following recommendations should be followed for copper data in high electrical noise environments:

- Data cable lengths should be as short as possible, ideally limited to 3m (10ft) in length. Copper data cables should not be used for inter-building communications.
- Power and data cables should not be run in parallel for long distances, and ideally should be installed in separate conduits. Power and data cables intersect at 90° angles when necessary to reduce inductive coupling.
- Shield/screened cabling can optionally be used. The cable shield should be grounded at one single point to avoid the generation of ground loops.

The DVS3000 can be equipped with IP video inputs. 8-port IP Camera Input cards are available with fiber optic SFP based LC connectors or RJ45 connectors. All ports support 100Mbps inputs.



Figure 5-1 8-Channle Camera Input card with RJ45 interface



Figure 5-2 8-Channel Camera Input card with SFP based LC fiber optic interface

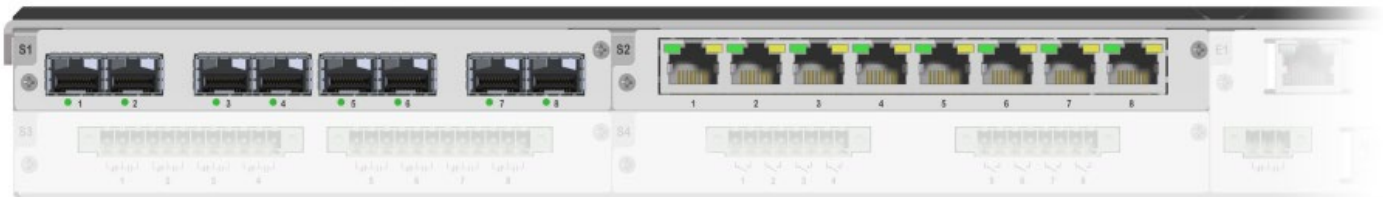

Figure 5-3 Partial view of DVS300 with camera input cards installed

6 RS485 Serial Interface

The unit is equipped with two RS485 serial ports that can be configured via SHCUtility software to operate in 2-wires mode (half-duplex) or 4-wires mode (full-duplex).

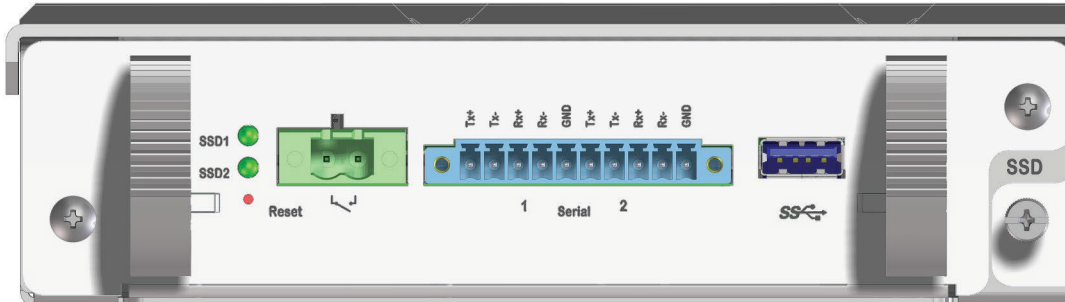

Figure 6-2 SSD Module

RS485: 2-wires		RS485: 4-wires	
Pin	Signal	Pin	Signal
1	CH #1: RX- (A)	1	CH #1: RX-
2	CH #1: RX+ (B)	2	CH #1: RX+
3	CH #1: TX+	3	CH #1: TX+
4	CH #1: TX-	4	CH #1: TX-
5	GND	5	GND
6		6	
7		7	
8		8	
9		9	
10		10	

Figure 6-1 SHC Utility Configuration

6.1 RS485 Half-duplex: 2-wires connections

Each RS485 port in 2-wires mode can communicate to multiple RS485 devices by daisy chaining devices over a single twisted pair with transmit and receive signals on the same two wires (half duplex). The following guidelines should be followed to ensure reliable continuous communication:

1. To minimize the effects of ambient electrical noise, shielded cabling is recommended.
2. The correct polarity must be observed throughout a single daisy chain.
3. The number of devices wired should not exceed 32, and total distance should be less than 4000 feet (at 100 kbps).
4. The Common terminals should be connected to the common wire inside the shield.
5. The shield should be connected to earth ground at a single point to avoid loop currents
6. The twisted pair should be terminated at each end of the chain.

Figure 6-3 shows the recommended RS485 wiring.

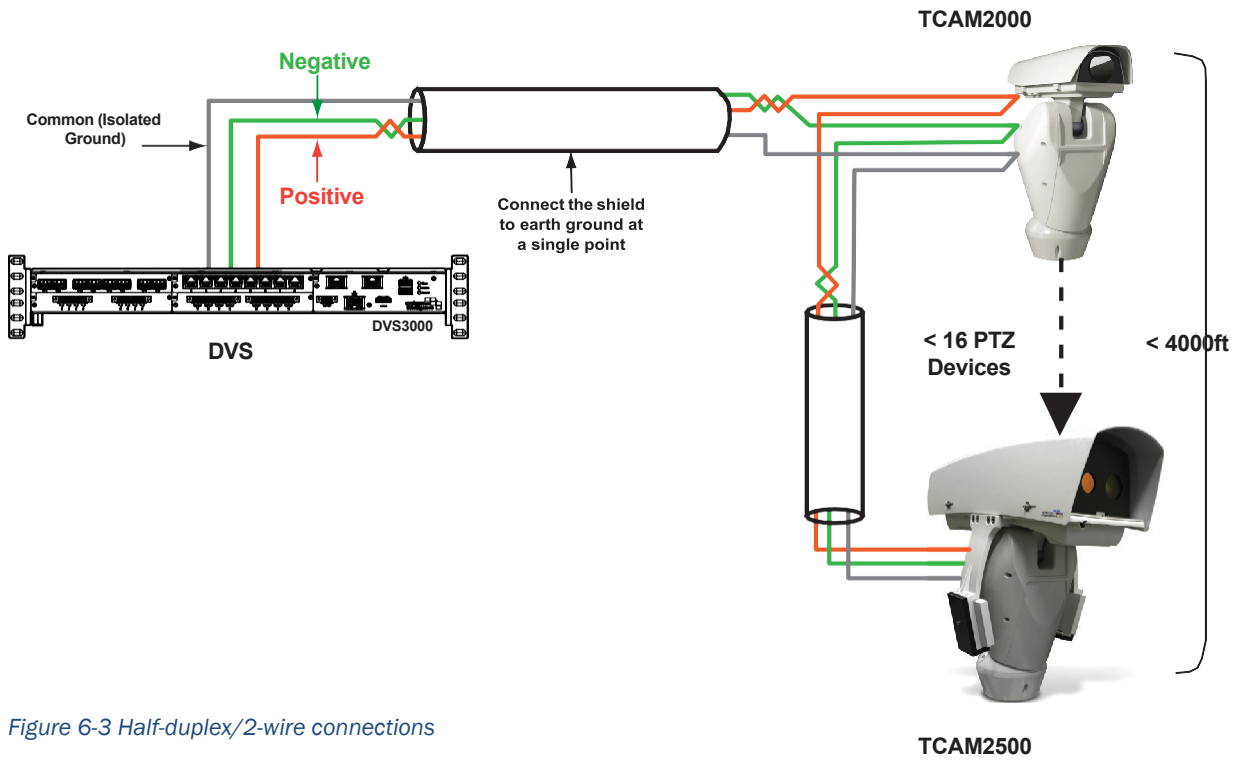

Figure 6-3 Half-duplex/2-wire connections

6.2 RS485-duplex: 4-wires connections

The serial ports can be configured for full-duplex communication. This requires 4-wires connection and is limited to point-to-point communication: DVS3000 to IED (Intelligent Electronic Device).

DVS3000	IED
RX-	TX-
RX+	TX+
TX-	RX-
TX+	RX+

Figure 6-4 4-wires connections

7 Digital I/O Interface

The DVS3000 is equipped with 2 modules that provide 8 digital inputs and 8 digital outputs. Each module provides 4 dry contact, current loop inputs and 4 relay switch outputs (30 VDC, 1 Amp / 50 VAC, 5 Amps).

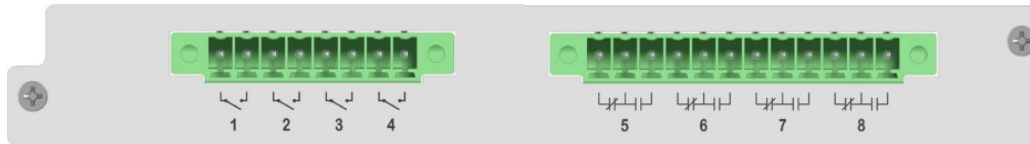

Figure 7-1 Digital Input-Output Module

7.1 Dry Contact Input Interface Connector

Connector Part Number: 1827923

Manufacturer: Phoenix

Description: Header, RA, 3.81mm pitch, Locking screws

Table 7-1 Dry Contact Input Interface Connector Pin Definition

PIN	SIGNAL	TYPE	CONNECTION
1	EXT_DRYCON1	I	Dry contact input signal
2	GND	P	Signal Ground
3	EXT_DRYCON2	I	Dry contact input signal
4	GND	P	Signal Ground
5	EXT_DRYCON3	I	Dry contact input signal
6	GND	P	Signal Ground
7	EXT_DRYCON4	I	Dry contact input signal
8	GND	P	Signal Ground

7.2 Relay Output Interface Connectors

Connector Part Number: 1827965

Manufacturer: Phoenix

Description: Header, RA, 3.81mm pitch, Locking screws

Table 7-2 Relay Interface Connector Pin Definition

PIN	SIGNAL	TYPE	CONNECTION
1	NO_RELAY1	O	Normally open relay output
2	COM_RELAY1	O	Common relay output
3	NC_RELAY1	O	Normally closed relay output
4	NO_RELAY2	O	Normally open relay output
5	COM_RELAY2	O	Common relay output
6	NC_RELAY2	O	Normally closed relay output
7	NO_RELAY3	O	Normally open relay output
8	COM_RELAY3	O	Common relay output
9	NC_RELAY3	O	Normally closed relay output
10	NO_RELAY4	O	Normally open relay output
11	COM_RELAY4	O	Common relay output
12	NC_RELAY4	O	Normally closed relay output

8 Ancillary equipment connections

The DVS3000 provides 2 functions that can be supported by ancillary equipment:

- Fail Safe Relay
- Remote Reset

8.1 Fail Safe Relay

The Fail-Safe Relay indicates if the DVS3000 is functioning properly. This is indicated via form-C contact that can be monitored and reported by an external device.

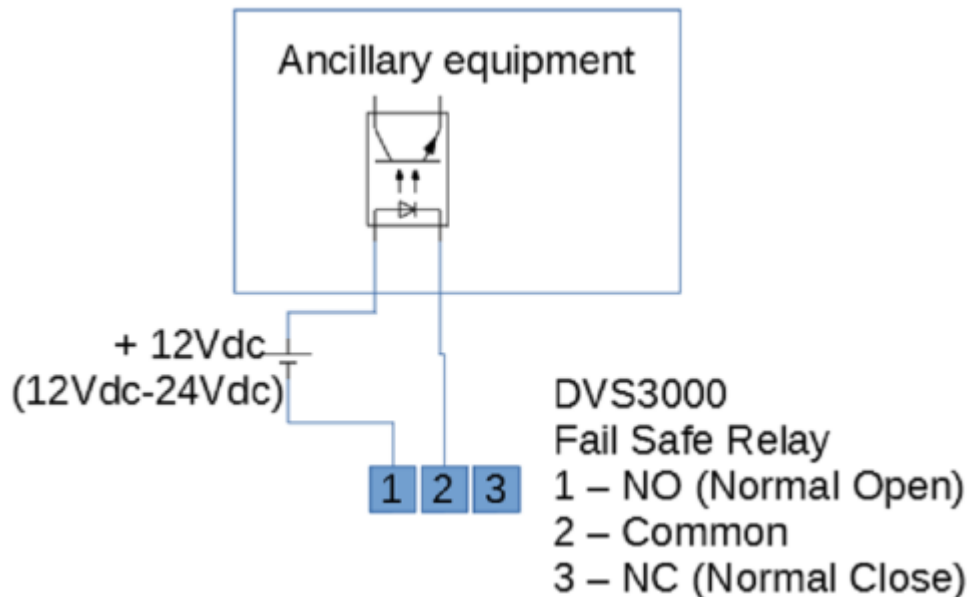

Figure 8-1 Fail Safe Relay Wiring

8.2 Remote Reset Input

The DVS3000 provides a digital input that acts as a Remote Reset Input. An external device located **no farther than 3m/12feet away** from the DVS3000 can activate this input via a relay output. Note: minimum required duration is 500msec. Also, for a easy access the unit provides a pin-hole reset located beside the Remote Reset Input connector.

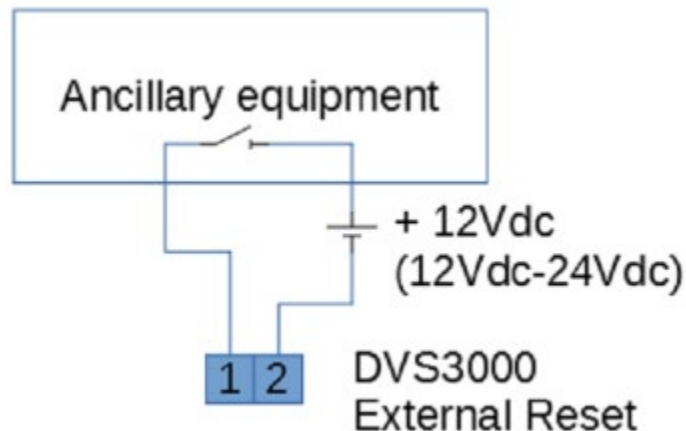

Figure 8-2 Remote Reset Input Wiring

9 Maintenance

9.1 Install/replace Power Supply Module

To install a new Power Supply module or to replace an existing Power Supply module follow the instructions.

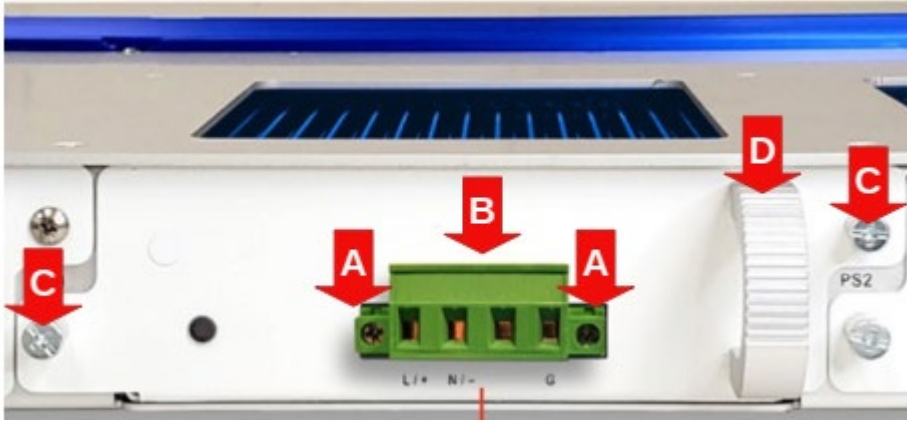

Figure 9-1 Power Supply Module

1. Power off the unit
2. Use Phillips screwdriver and unscrew the connector's screws marked (A) on Figure 9-1.
3. Unplug the connector marked (B) in Figure 9-1.
4. Use your fingers and loose screws marked (C).
5. Grab bracket marked (D) and pull until the module is completely out.
6. Insert new Power supply module and push until it is fully inserted. Verify that the label on the Power Supply Module is matching the supply voltage.
7. Screw the thumb screws (C).
8. Insert connector (B)
9. Screw with a Phillips screwdriver screws (A)
10. Power on the unit and wait for the unit to start. Check the power supply status reported by the front LEDs.

9.2 Install/replace Hard Disk

To install a new Hard Disk or to replace an existing Hard Disk module follow these instructions.

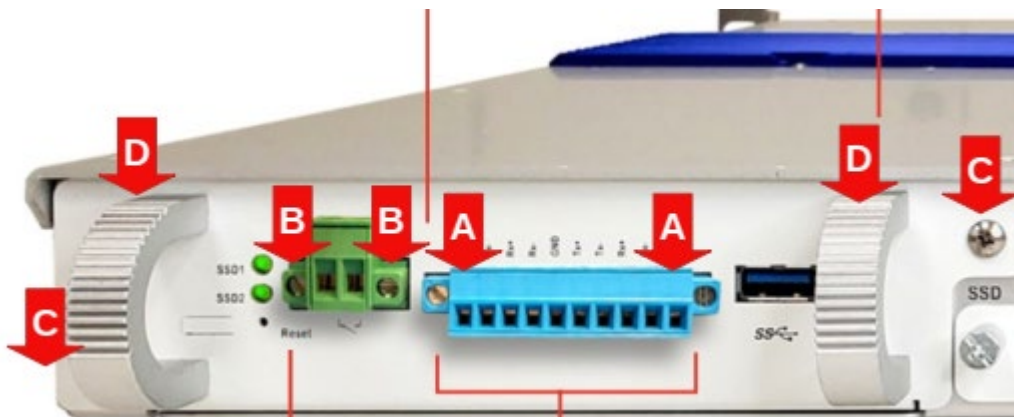

Figure 9-2 SSD Module

1. Power off the unit
2. Use Phillips screwdriver and unscrew the connector's screws marked (A) on Figure 9-2. If you have wiring on this connector, unplug it.
3. Use Phillips screwdriver and unscrew the connector's screws marked (B) on Figure 9-2. If you have wiring on this connector, unplug it.
4. Use your fingers and loose screws marked (C) on Figure 9-2.
5. Grab bracket marked (D) and pull until the module is completely out.

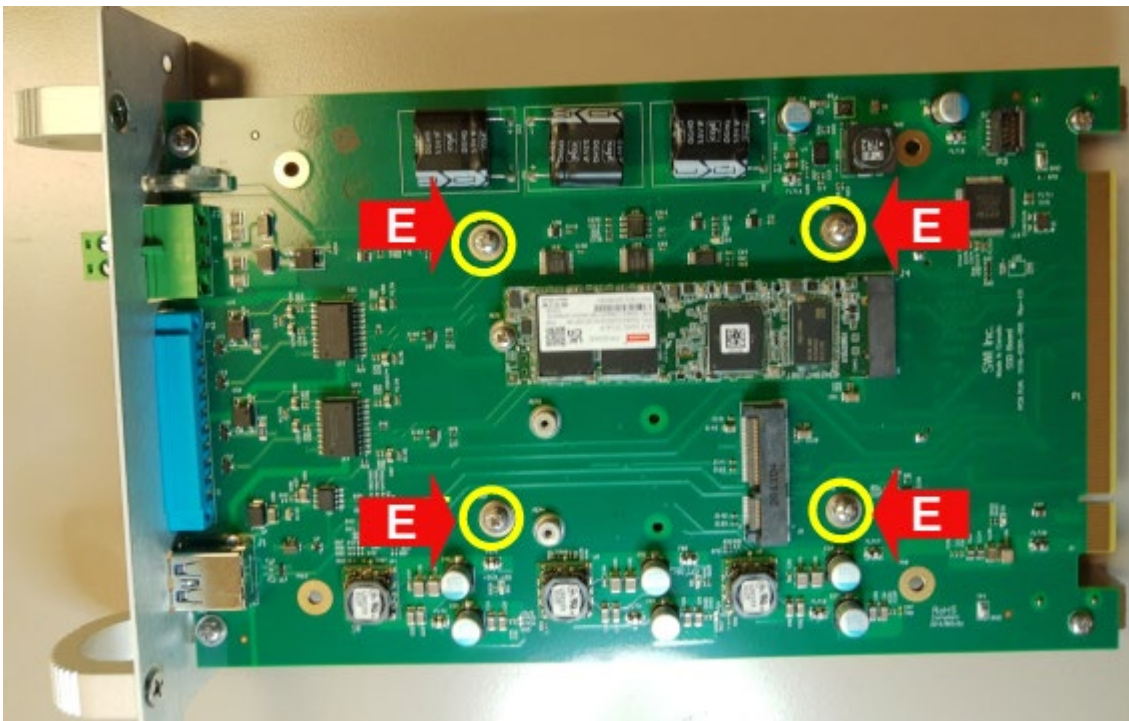

Figure 9-3 Internal view SSD Module

6. Unscrew screws marked (E) in Figure 9-3.
7. Slide and remove the Hard Disk marked (F) in Figure 9-4.
8. Position the Hard Disk and slide into connector (G) in Figure 9-4.
9. Screw back (E).
10. Insert new SSD module and push until it is fully inserted.

11. Screw the thumb screws (C).
12. Insert connectors (A) and (B).
13. Screw with a Phillips screwdriver screws (A) and (B).
14. Power on the unit and wait for the unit to start.

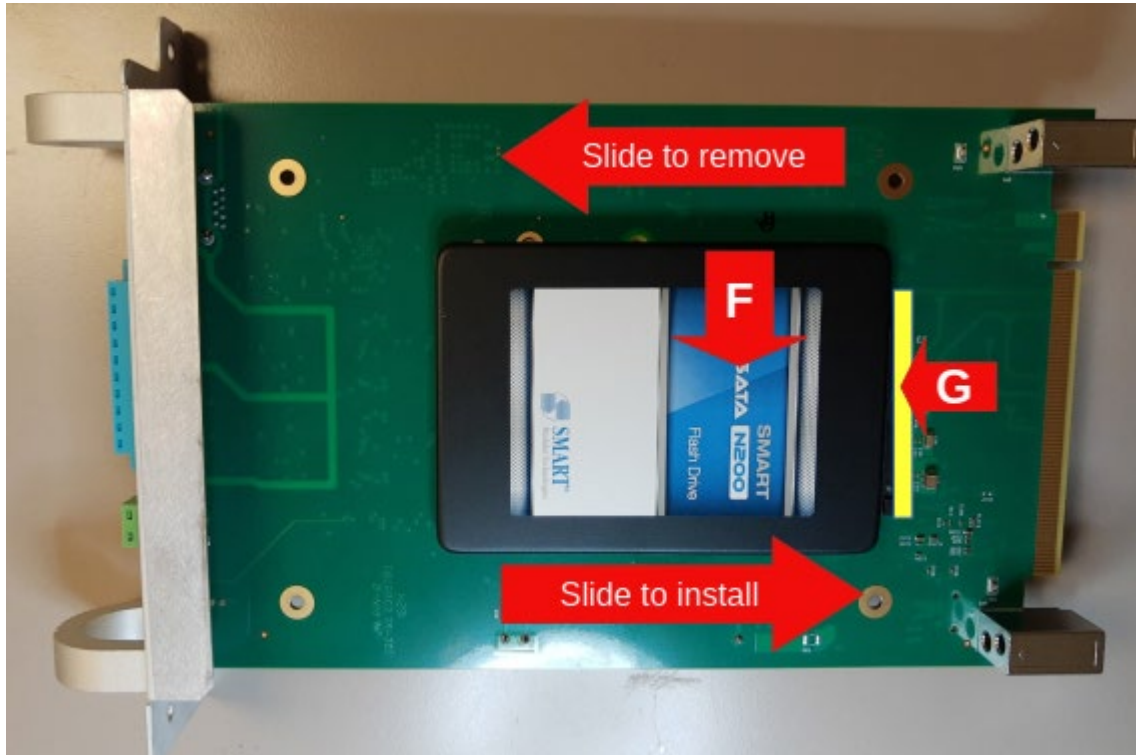

Figure 9-4 Hard Disk position in SSD Module

10 Environmental Specifications

This section summarizes the environmental specifications that the DVS3000 has been designed to meet.

10.1 Temperature & Humidity

Table 10-1 Temperature and Humidity Limits

FUNCTION	DESCRIPTION	SPECIFICATION
IEC 60870-2-2	Cold Operation	- 40 °C, 16 hours
	Dry Heat Operation	+85 °C, 16 hours
	Cold Storage	- 40 °C, 16 hours
	Dry Heat Storage	+85 °C, 16 hours
	Damp Heat Test	+95%, +40 °C, 96 hours

10.2 EMC/EMI/ESD

1. IEC 61850-3 Electric Utility Substations
2. IEEE 1613 Electric Utility Substations
3. IEC 61000-6-2 Industrial (Generic)
4. CISPR FCC Part 15 Class A (Conducted and Radiated Emission)

Note: EMI Type test levels are only valid for High Voltage power supply.

10.3 EMI TYPE TESTS

Table 10-2 EMI Type Tests

TEST	DESCRIPTION	TEST LEVELS	
IEC 61000-4-2	ESD	Enclosure Contact	+/- 8KV
		Enclosure Air	+/- 15KV
IEC 61000-4-3	Radiated RFI	Enclosure ports	20 V/m
IEC 61000-4-4	Burst (Fast Transient)	Signal ports	+/- 4KV @ 5KHz, 1 min
		D.C. Power ports	+/- 4KV @ 5KHz, 1 min
		A.C. Power ports	+/- 4KV @ 5KHz, 1 min
		Earth ground ports	+/- 4KV @ 5KHz, 1 min
IEC 61000-4-5	Surge	Signal ports	+/- 2KV line-to-earth
		D.C. Power ports	+/- 4 KV line-to-earth, +/- 2KV line-to-line
		A.C. Power ports	+/- 4 KV line-to-earth, +/- 2KV line-to-line
IEC 61000-4-6	Induced (Conducted RFI)	Signal Ports	10V
		D.C. Power ports	10V
		A.C. Power ports	10V
		Earth ground ports	10V
IEC 61000-4-8	Magnetic Field	Enclosure ports	100 A/m continuous, 1000 A/m for 1s
IEC 61000-4-29	Voltage Dips & Interrupts	D.C. Power ports	100 VDC-30% 100 VDC-60% 100 VDC-100% 100 VDC+/-20% 300 VDC-30% 300 VDC-60% 300 VDC-100% 300 VDC+/-20%
IEC 61000-4-11		A.C. Power ports	230 VAC-20% 230 VAC-70% 230 VAC-100% 120 VAC-30% 120 VAC-60% 120 VAC-70% 120 VAC-100%
IEC 61000-4-16	Main Frequency Voltage	Signal ports	30V Continuous, 300V for 1s
		D.C. Power ports	30V Continuous, 300V for 1s
IEC 61000-4-17	Ripple on D.C. Power Supply	D.C. Power ports	15% of rated voltage
IEC 60255-5	Dielectric Strength	Signal ports	705 VDC, 1 min (Ethernet) 2828 VDC, 1 min (Relay) 705 VDC, 1 min (Relay Contacts)
		D.C. Power ports	2828 VDC
		A.C. Power ports	2828 VDC
IEC 60255-5	H.V. Impulse	Relay Signal ports	5KV
		D.C. Power ports	5KV
		A.C. Power ports	5KV

10.4 EMI IMMUNITY TYPE TESTS

Table 10-3 IEEE 1613 (C37.90.x) Immunity Type Tests

TEST	DESCRIPTION		TEST LEVELS
IEEE C37.90.3	ESD	Enclosure Contact	+/- 2KV, +/- 4KV, +/- 8KV
		Enclosure Air	+/- 4KV, +/- 8KV, +/- 15KV
IEEE C37.90.2	Radiated RFI	Enclosure ports	20 V/m
IEEE C37.90.1	Fast Transient	Signal ports	+/- 4KV @ 2.5KHz
		D.C. Power ports	+/- 4KV
		A.C. Power ports	+/- 4KV
		Earth ground ports	+/- 4KV
IEEE C37.90	Dielectric Strength	Signal ports	2828 VDC, 1 min
		D.C. Power ports	2828 VDC, 1 min
		A.C. Power ports	2828 VDC, 1 min
IEEE C37.90	H.V. Impulse	Signal ports	5KV
		D.C. Power ports	5KV
		A.C. Power ports	5KV



DVS3000 INSTALLATION GUIDE

Version 1.0



Follow Us:



SYSTEMS WITH INTELLIGENCE INC..



Systems With Intelligence Inc
6889 Rexwood Road, Unit 9
Mississauga, ON, Canada
L4V 1R2

P : +1-289-562-0126
F : +1-289-562-0152
W : www.systemswithintelligence.com
M : support@systemswithintelligence.com

All specifications in this document are subject to change without notice.